

PART NUMBER **28-22007**

**Burly**  
B R A N D

HARLEY -DAVIDSON® DYNA 1" LOWERING KIT

#### WARNINGS & ALERTS

- This kit is designed to accept Harley-Davidson OEM shocks and OEM tire size ONLY. DO NOT USE WITH LOWERED SHOCKS!!!
- This kit is not recommended for the models that are lowered from the factory.
- To maintain proper balanced geometry, we recommend lowering the front and rear of the motorcycle equally. See your local dealer for Burly Brand front lowering kit options.
- The operator must use extreme caution when operating a modified motorcycle, particularly while familiarizing himself with its altered handling characteristics and reduced ground clearance.
- Enclosed sticker must be applied to a visible area of any motorcycle on which the Burly Brand lowering kit has been installed in order to inform potential riders that the bike has been modified.

#### TOOLS REQUIRED

- 1200 lb. Capacity Lift
- 3/4" Wrench
- 3/4" Socket, T50 Torx Socket & Ratchet
- 5/16" Allen Wrench or Socket
- 1/2"-13 Tap and Handle
- Thread locking compound (Loctite 243)

#### INSTALLATION INSTRUCTIONS

- Read all the instructions carefully before installing this kit on your motorcycle. Use your Harley-Davidson manual as a reference while installing this kit.
- Support and lift the motorcycle securely so the rear wheel is just off the ground and able to spin with light brake drag. The balance point is between the engine and transmission.
- Loosen the upper shock bolts. Remove the lower shock bolt and washers. Save these parts as, aside from the nut on the left hand side, they will be re-used with this kit.
- Using the 1/2-13 Tap, chase the threads in the casting where the right shock mounts to the swingarm. Make sure that the threads continue all the way through the hole as we will be bolting the bracket from the back side.
- Using the thread locking compound and the supplied 1/2" X 1-1/2" Hex bolt and washers install the right lowering bracket to the inside of the swingarm at the shock mount boss (figure 1).



Figure 1

- Please note that each kit comes with a left and right bracket.
- Using the Thread locking compound and supplied  $\frac{1}{2}$ " X 1-1/2" Hex bolt and washers install the left lowering bracket to the inside of the swingarm at the shock mount boss (figure 2).
- Using the Thread locking compound re-install the stock bolt and washer, but do not fully tighten.
- Repeat procedure on the left side shock.
- Remove motorcycle from the lift and tighten all three bolts to 40 ft/lbs using a torque wrench.
- Check the spring preload on the shocks. Adjustment may be necessary for some people, depending on their weight and ride preference (soft or stiff). Read owners manual for procedure.

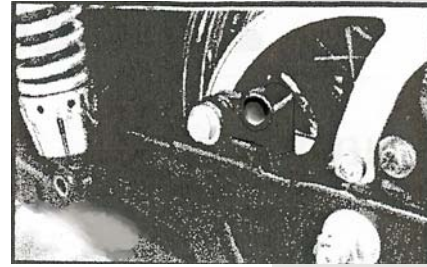
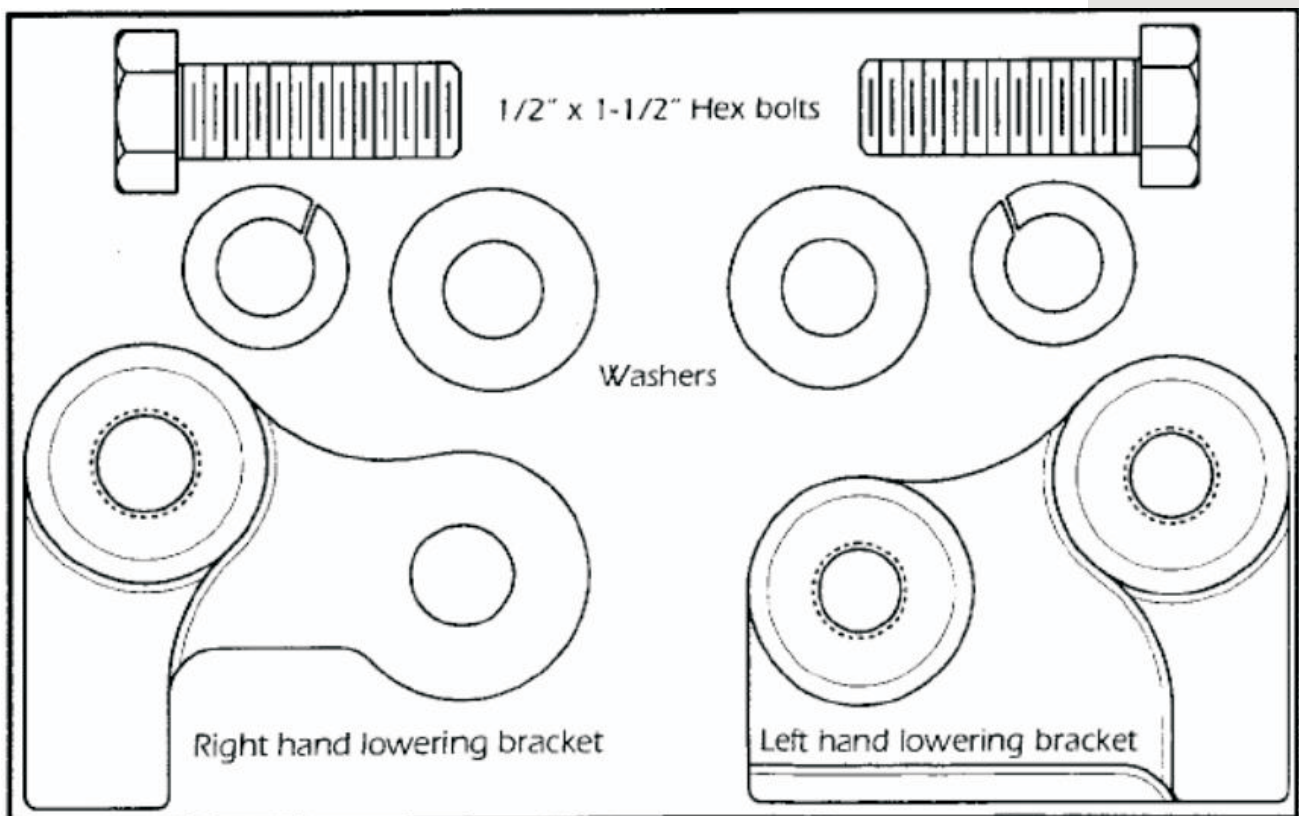

Figure 2

## PARTS LIST



## LIMITED GUARANTEE

We continually inspect and try to improve our products. All parts have been inspected prior to packaging, and our guarantee is limited to replacement of defective parts. This guarantee is in lieu of all guarantees or warranties implied or expressed. Because we cannot control the application of our products, buyer assumes risks for any and all damage caused by himself or third party, by virtue of failure of these parts. We make no warranty as to products distributed by us, expressed or implied, including without limitation any warranties or merchant ability and fitness for a particular purpose. We will however, pass on all warranties made by the manufacturer, who has sole responsibility for performing such warranties. The manufacturer shall solely be responsible for any damage to person or property arising from design, manufacturing and testing of all products, and we accept no liability for such damages. We shall not be liable for indirect or consequential damages.