

INSTRUCTION

HIGH PERFORMANCE OIL PUMP

for Harley Davidson TC88 engine
1999-2005FXD / 1999-2006FXST,FLST,FLT

Thank you for purchasing DAYTONA OIL PUMP KIT.

Product Features

- 171% feed volume and 191% scavenge volume compared to OEM stock TC88 oil pumps. (1000rpm)
- 213% feed volume and 236% scavenge volume compared to OEM stock TC88 oil pumps.(2500rpm)
- High-pressure die-cast aluminum body and high strength sintered Metal Gear construction.
- 53mm diameter rotors for maximum performance.



1. Read all instructions before use.
2. Measure flywheel shaft run out. When the flywheels shift, the pinion shaft wobbles, causing damage to the oil pump, cam support plate, and other cam related parts. The recommended maximum run out tolerance is 0.003"
3. After installation, check to see if all the parts are correctly installed, and see if all the screws are torqued properly.
4. If anything unusual may be found while driving,pull over at a safe place to check.

Install

1. See the service manual for oil pump installation.
2. See the parts catalog for each model.
3. Have to use 4pcs of ⑪ 1/4-20(L=1"1/4) screw for DAYTONA OIL PUMP.
4. Do not use the mount screws of Original one.
5. Final tighten four(4), OIL PUMP mount screws to 90-120in-lbs (10.2-13.6Nm)

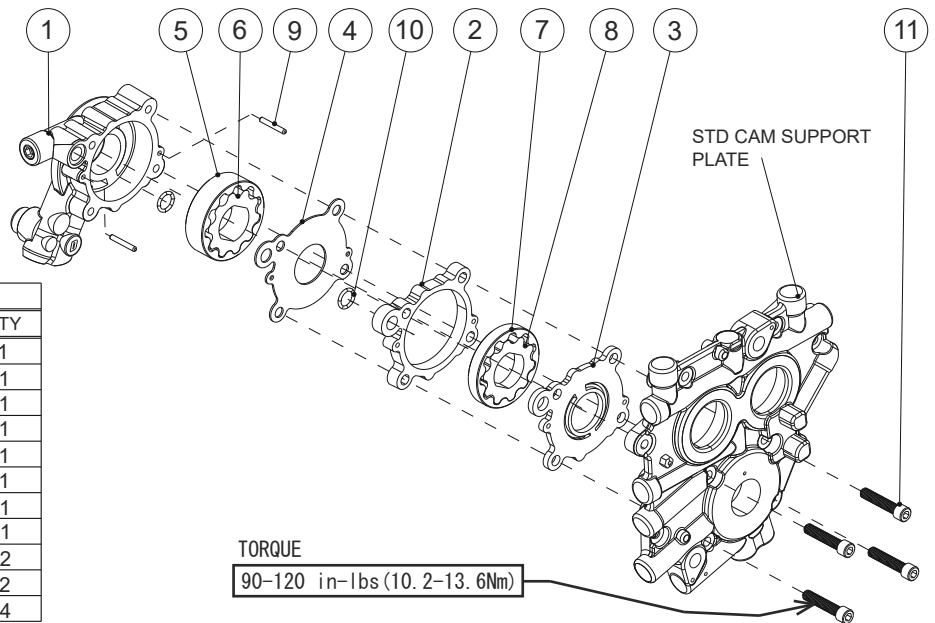

PARTS LIST		
	DESCRIPTION	QTY
1	BODY 1,PUMP	1
2	BODY 2,FEED	1
3	SPACER	1
4	SEPARATOR	1
5	ROTOR SCAVENGE,OUTER	1
6	ROTOR SCAVENGE,INNER	1
7	ROTOR FEED,OUTER	1
8	ROTOR FEED,INNER	1
9	PIN	2
10	O-RING	2
11	CAP BOLT / 1/4-20 x 1-1/4	4

SERVICE DATA

	POSITION	DESCRIPTION	STANDARD	SERVICE LIMIT
A		Gap between inner rotor and outer rotor	0.0059 inch	0.0078 inch
			0.15 mm	0.2 mm
B		Clearance between outer rotor and oil pump housing	0.0055 - 0.0070 inch	0.0125 inch
			0.14 - 0.18 mm	0.32 mm

SPARE PARTS

