



HIGH PERFORMANCE A/C ASSEMBLY

For technical support contact Joker Machine

2245 Kiowa Blvd N. Ste. 100, Lake Havasu City, AZ 86403
PHONE: 909-596-9690, FAX: 909-596-9693
sales@jokermachine.com, www.jokermachine.com

REQUIRES

Sportster:

- 1/4" 12 Point Wrench
- 1/2" 12 Point Wrench
- 3/16" Allen Wrench

Softail:

- 1/4" 12 Point Wrench
- 3/8" 12 Point Wrench
- 3/16" Allen Wrench

IMPORTANT: A/C assembly will not run properly without re-mapping the E.F.I. system or re-jetting the carburetor.

NOTE: Use BLUE LOCTITE on all hardware

INSTALLATION

1. Completely remove stock air cleaner assembly. Keep stock gasket for step 3.
2. Softail version only: Secure the loose pigtail with a zip-tie to the throttle position switch wiring harness.
3. Install base plate with (3) 1/4"-20 x 5/8" Allen screws using blue Loctite to the throttle body with the stock a/c gasket. do not completely tighten down.
4. Install vent plates, vent tubes (if using), stand-offs and washers with breather bolts.
(use blue Loctite on breather bolts)
⚠ NOTE! DO NOT OVER TIGHTEN BREATHER BOLTS
5. Fully tighten base plate screws.
6. Install the outer cover, K&N filter, and stand-off with the 1/4"-20 x 2-1/2" 12 point bolt using blue Loctite.
NOTE: Over tightening will crush K&N Filter.
7. Re-map EFI system or re-jet carburetor for increased air flow.

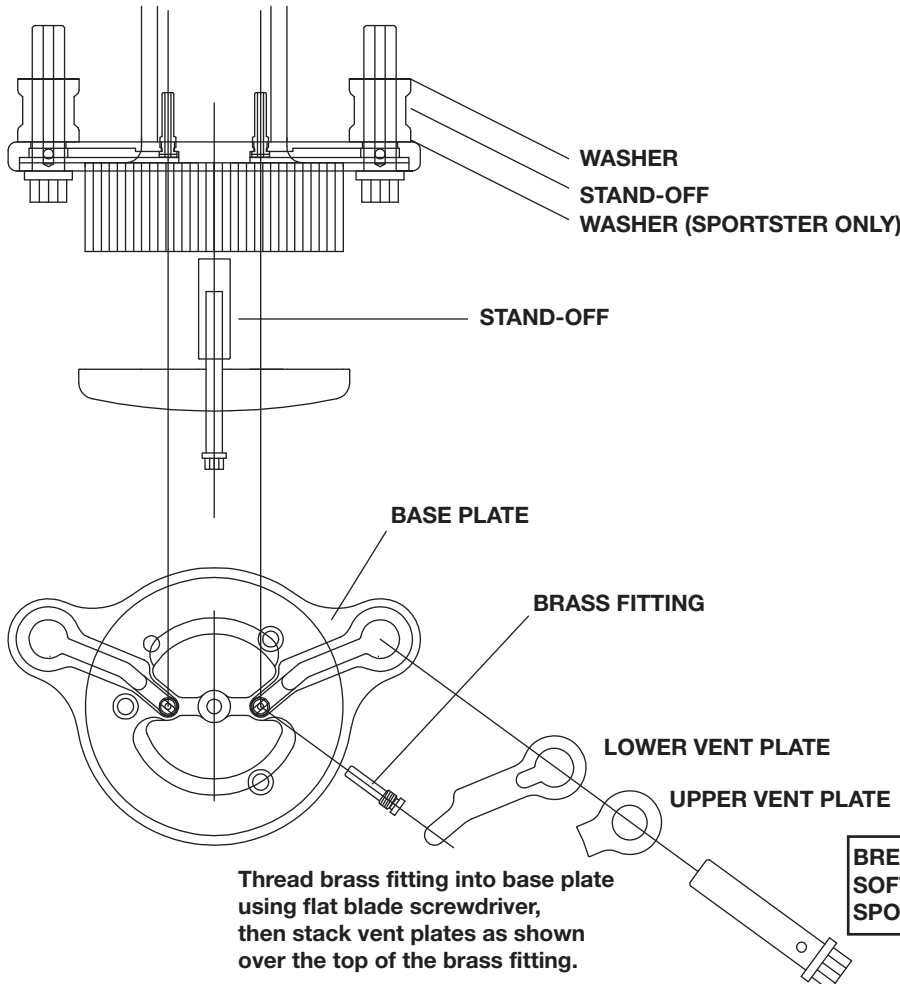

**DO NOT OVER TIGHTEN
BREATHER BOLT!
Use a dab of blue Loctite**

BREATHER BOLT
SOFTAIL: 3/8"-16 X 2-3/4"
SPORTSTER: 1/2"-13 X 2-1/2"