

The Nation's Cycle Center

N2200/01/02/03 Installation Instructions ••• Hardcoated Polycarbonate Vintage Windshield

ITEM	PART NUMBER	DESCRIPTION	QTY.
1	30-320004-000	STRIP ASS'Y, INSIDE, HORIZONTAL, VINTAGE, BLACK	1
2	34-343412-000	UPRIGHT, THREADED, 3/8" ROD, 2-BEND, VINTAGE WS; BLACK	2
3	42-482000-000	CAP NUT, 5/16"-24	2
4	49-491301-000	WASHER, SPLIT, 5/16" HD#7401	2
5	55-565118-000	MS, OVAL, SLOT, 8-32 x .75 LG	5
6	42-482221-000	CAP NUT, HEX, 8-32, STAINLESS	5
7	30-310004-000	STRIP, OUTSIDE, HORIZONTAL VINTAGE WS, BLACK	1
8	34-340017-000	WIRE, FORMED, LOWER, VINTAGE WS, ELECTROPOLISHED	1
9	30-300008-000	LOOP CLAMP	4
10	34-340016-000	WIRE, FORMED, UPPER, VINTAGE WS, ELECTROPOLISHED	1
BAG #1366			
11	52-521001-000	EYEBOLT, 3/8" HOLE, 1-1/16" THD L, VINTAGE WS, BLACK	2
12	49-496101-000	SLEEVE, ROD CLAMP SEAT, VINTAGE WS	2
13	37-370694-00	BRACKET, INCHWORM, VINTAGE WS, CLAMP, 2-HOLE, BLACK	4
14	49-492211-000	WASHER, INT., 5/16", CHROME	2
15	50-503200-000	CAP SCREW, 5/16"-24x1, CHROME	2
16	49-492220-000	WASHER, INT., 7/16", CHROME	2
17	42-422030-000	HEX NUT, 7/16"-20	2
18	42-451101-000	HEX NUT, 5/16"-24	2
19	20-290815-000	UPPER WINDSHIELD, QUANTUM HARDCOATED POLYCARBONATE	1
20	20-290900-000	LOWER WINDSHIELD - CLEAR N2200	*
20	20-290902-000	LOWER WINDSHIELD - RED N2201	*
20	20-290810-000	LOWER WINDSHIELD - BLUE N2202	*
20	20-290901-000	LOWER WINDSHIELD - BLACK N2203	*
21	49-495601-000	BUSHING, TOP HAT, .50 OD x .156 ID x .181 LG, VINTAGE WS, STAINLESS	4
22	55-565153-000	MACHINE SCREW, OVAL SLOT, 6-32 x .38 LG	4
23	42-480010-000	CAP NUT, 6-32, STAINLESS	4
24	30-300009-000	CLIP BEADING, BLACK	2
25	75-751397-000	WARNING LABEL	1

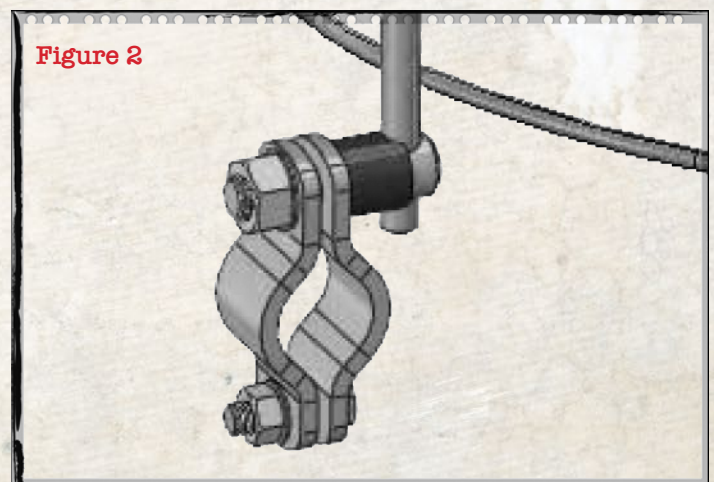
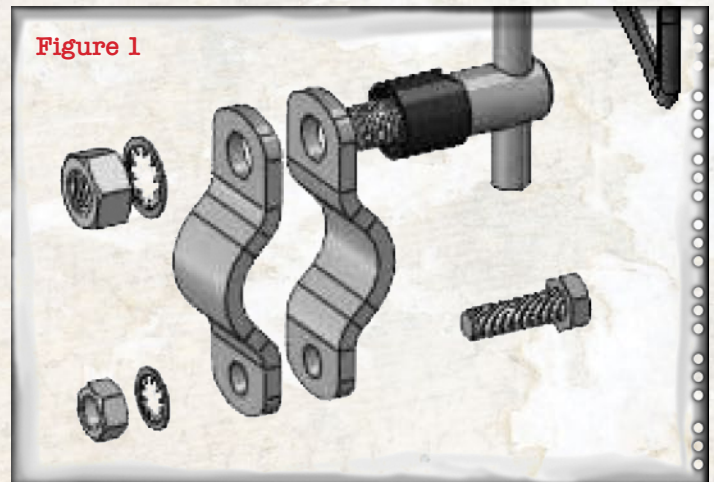
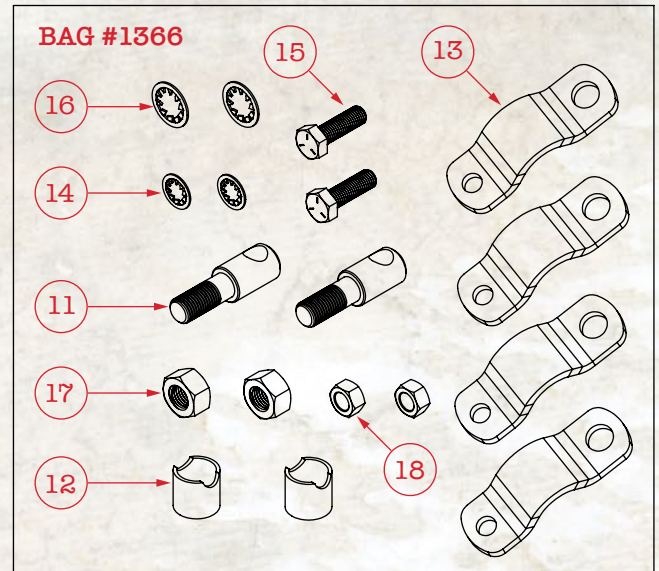

See next page for schematic windshield diagram.

The Nation's Cycle Center

N2200/01/02/03 Installation Instructions ••• Hardcoated Polycarbonate Vintage Windshield

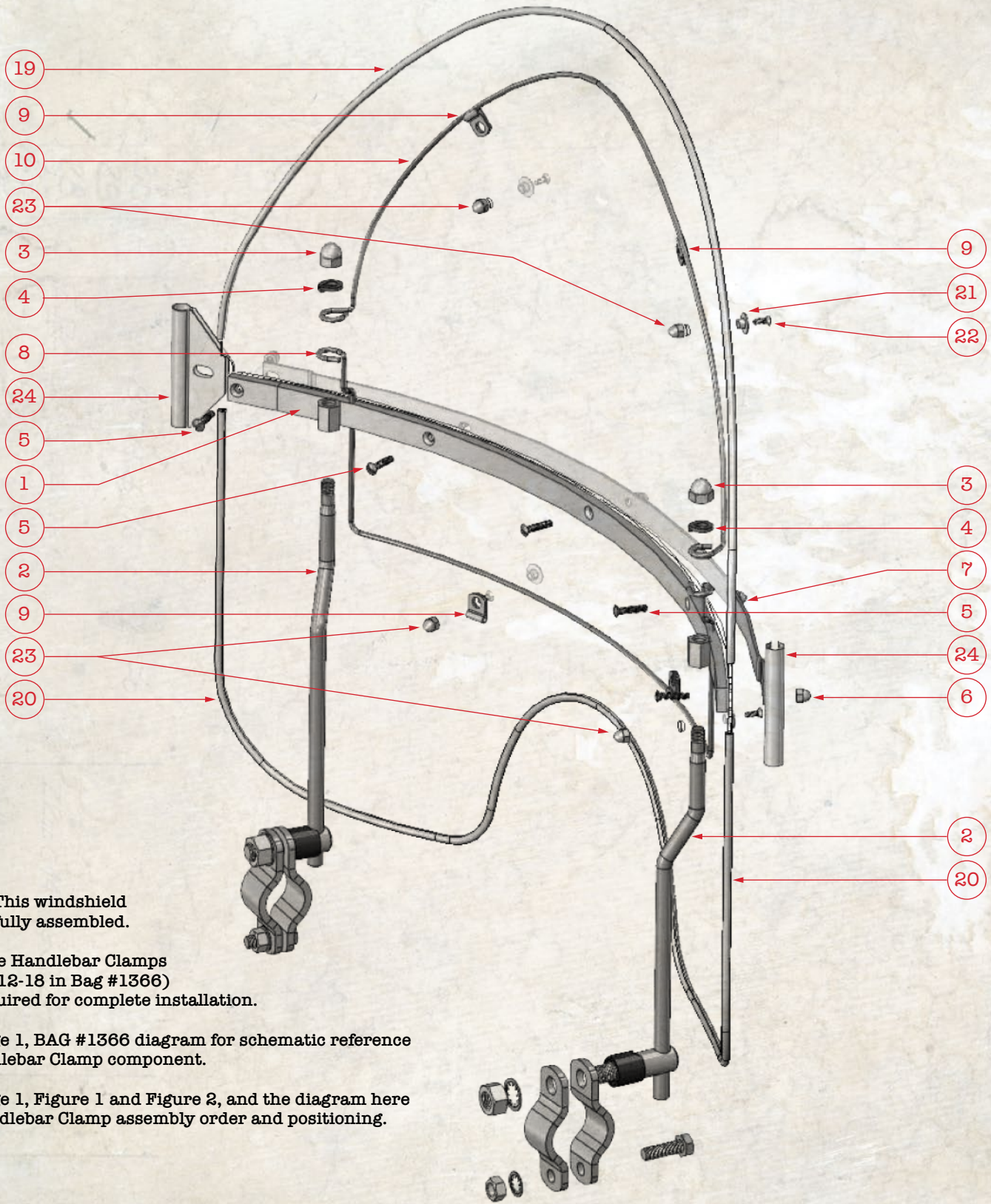

NOTE: This windshield comes fully assembled.

Only the Handlebar Clamps (Items 12-18 in Bag #1366) are required for complete installation.

See Page 1, BAG #1366 diagram for schematic reference of Handlebar Clamp component.

See Page 1, Figure 1 and Figure 2, and the diagram here for Handlebar Clamp assembly order and positioning.

Your new Vintage Beaded Windshield comes fully assembled, so all you need to do is install the Handlebar Bracket Clamps.

Note: The Threaded Uprights (2) on the back of the windshield can be loosened at the top (5/16" Wrench) to swivel into a different position to vary the center-to-center width to match eligible mount points on your handlebars. Make sure you re-tighten the Cap Nuts (3) when you have your optimal settings.

Hold the windshield up to your bike (**Figures 3-4**) and note where the Threaded Uprights meet the handlebars and mark those locations.

Open BAG #1366 and sort the components (**see BAG #1366 Parts List on Page 1**). Before installing the Bracket Clamps, wrap the handlebar mount locations with electrical tape, friction tape, or a one-inch section of bicycle inner tubing to protect the handlebar's finish.

Assemble Bracket Clamps to the handlebars (**Page 1, Figures 1-2**) but leave all bolts and hex nuts just finger-tight for now.

Slide the windshield's Uprights into the Eyebolts (11) of the Bracket Clamps. The Bracket Clamps may need to be rotated forward or back, or slightly repositioned so that the windshield sets at the proper angle and 2-3 inches above the headlight.

Progressively tighten the hardware in small increments as you refine the windshield's position (**Figure 5**). When you are satisfied, tighten all hardware firmly and securely (5/16" Wrench).

Your windshield installation is complete (**Figure 6**). Now it's time to go for a ride.



Figure 3



Figure 4

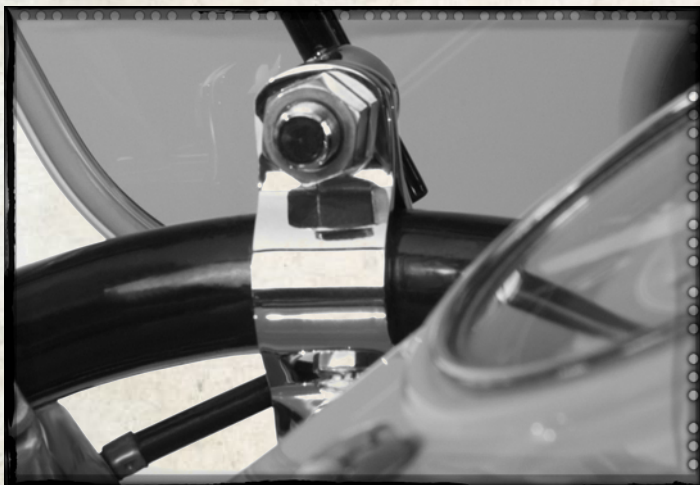

Figure 5

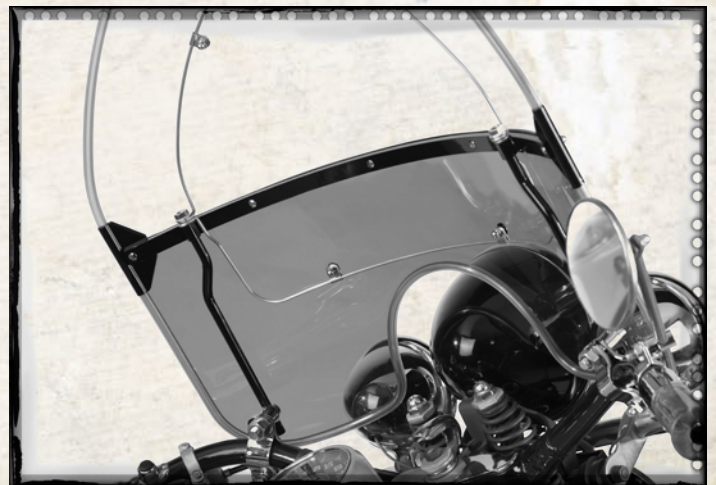
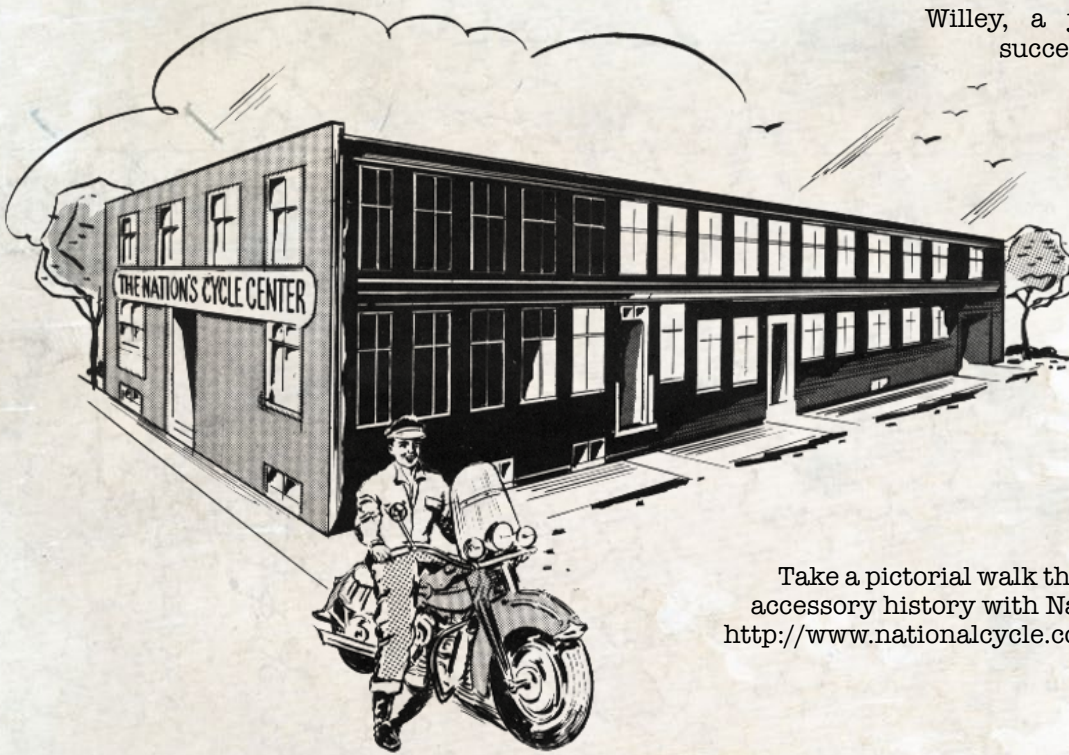

Figure 6

The company known today as National Cycle started in Chicago, Illinois in 1937 as Nation's Cycle Center. The company was founded by Gordon Willey, a young man who believed that success in business required "Total Customer Satisfaction".



This business philosophy was the beginning of a long and successful tradition. It's a tradition we maintain today as we continue building the finest motorcycle windshields and accessories a rider can own.

Today, National Cycle is the world leader in motorcycle windshield manufacturing, with more distribution than any other windshield company in the world.

Take a pictorial walk through over 80 years of motorcycle accessory history with National Cycle, starting here:
<http://www.nationalcycle.com/about-us/timeline/1937-1945>



Register Your Windshield Online at www.nationalcycle.com

National Cycle 3-Year Limited Warranty

National Cycle hereby warrants to the original registered owner of a National Cycle polycarbonate windshield for a period of three years from the date of purchase against breakage. This limited warranty is expressly limited to the replacement of the polycarbonate windscreen. This limited warranty does not include scratches, coating failure, cosmetic wear and tear, replacement of hardware, or any consequential damages or expenses including labor cost of installation, removal and/or replacement, inconvenience, inbound freight expenses or damage to any other component of the motorcycle or any other accessories. Certain chemicals, generally known as acidic hydrocarbons, are known to cause polycarbonate damage and will not be covered under this limited warranty. Please refer to the cleaning instructions supplied with all National Cycle windshields.

Visit www.nationalcycle.com for further details, or call or e-mail National Cycle.



WARNING

Never ride your motorcycle with loose accessory mounting hardware. Check the hardware for tightness regularly.

Modern motorcycles are built to withstand the loads imposed on them by the foreseeable addition of common motorcycle accessories. If an accessory(ies) adversely affects your motorcycle's stability, immediately remove the accessory(ies). Do not ride a motorcycle that exhibits unsafe handling traits. Have experienced service personnel correct any problem before riding with the accessory(ies) installed. For further questions concerning handling problems associated with an accessory(ies), contact your dealer, motorcycle manufacturer, or accessory manufacturer.

Sunlight reflected off the inside curvature of the windscreen can, at certain times of day, cause extreme heat buildup on the motorcycles instruments and possibly even melt them. Exercise care in parking to avoid this. Park your motorcycle facing the sun or place an opaque object over this area.