



AIRCHARGER[®]

HIGH-FLOW INTAKE KITS

NOT LEGAL FOR SALE OR USE ON ANY POLLUTION CONTROLLED MOTOR VEHICLE IN CALIFORNIA OR STATES ADOPTING CALIFORNIA EMISSION PROCEDURES.

See knfilters.com for CARB status on each part for a specific vehicle

INSTALLATION INSTRUCTIONS

63-1134

HARLEY DAVIDSON

SEE CATALOG OR KNFILTERS.COM FOR CURRENT APPLICATIONS

TOOLS NEEDED:

- 3/16" Allen Wrench
- 5/16" Allen Wrench
- 1/4" Allen Wrench
- 3/32" Allen Wrench
- 7/16" socket
- 5/16" Wrench
- Extension
- Flat Blade Screwdriver
- Ratchet
- T27 Torx Socket

PARTS LIST:

Description	Qty.	Part #
A Gasket; Harley Davidson	1	09708
B O-Ring; 9/16" ID, .10 Thick	4	07761
C Back Plate; Harley Davidson	1	63-1134-2
D Breather Bolt	2	22237
E Screw; 1/4-20 x 3/4" SOC.	3	07731
F Thread Locker	1	482
G Gasket; 63-1134	1	63-1134-3
H 10-32 x 7/8" Cup Point Set Screw	4	22238
I Intake Tube	1	63-1134-1
J Hose Clamp #48	1	08601
K Air Filter	1	RE-5286
L Washer; Flat #10 SS	4	08257
M Washer; Lock #10 SS	4	22241
N 10-32 Cap Nut SS	1	22239

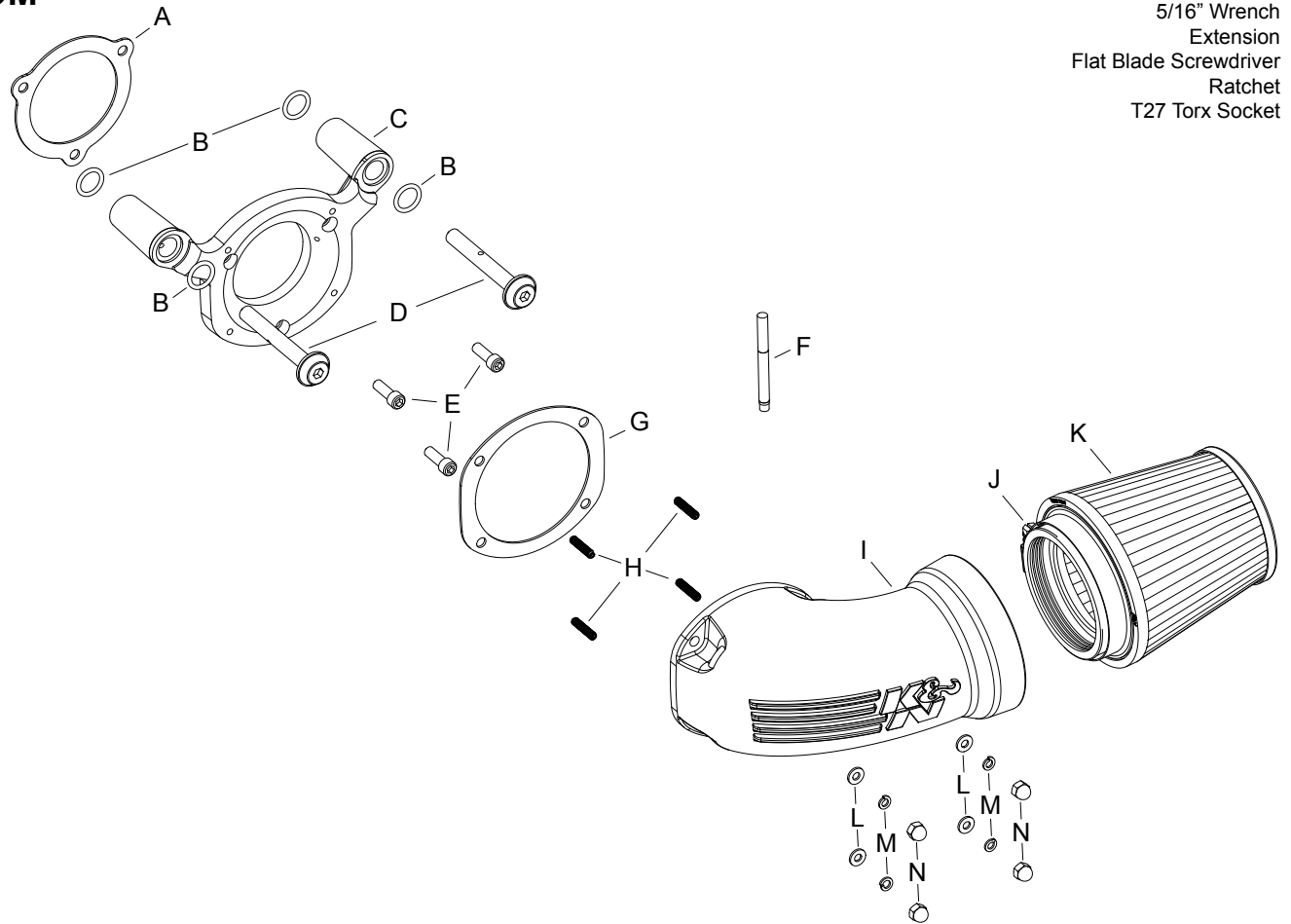

If you need any assistance please call 1-800-858-3333 to speak with a representative in our Customer Service Center before returning the product.

NOTE: FAILURE TO FOLLOW INSTALLATION INSTRUCTIONS AND NOT USING THE PROVIDED HARDWARE MAY DAMAGE THE INTAKE TUBE, THROTTLE BODY AND ENGINE.

TO START:

1. Turn off the ignition and disconnect the negative battery cable.



2. Some models have a number plate attached with Velcro. Firmly grip right side edge of number plate and pull off.



3. Remove air filter cover bolt and air filter cover as shown.



4. Loosen the three air filter retaining bolts as shown.



5. Remove the air filter from the vehicle and disconnect the crankcase breather tubes.



6. Remove the two breather/air filter base mounting bolts as shown.

NOTE: K&N[®] Engineering, Inc. recommends that customers do not discard the factory air intake components.



7. Remove the air filter base from the vehicle as shown.



8. Install two of the o rings provided onto the back side of the K&N® back plate as shown.



9. Install the remaining two o rings onto the front of the back plate as shown. Install the four provided studs with thread locker positioned into the back plate.



10. Using the two provided crankcase breather bolts; install the back plate onto the vehicle. Do not tighten bolts at this time. Install the provided gasket between the throttle body and back plate and then secure with provided hardware.

NOTE: Apply one drop of the provided thread locker onto the bolts.



11. Install the K&N® intake tube with the gasket and provided hardware.

NOTE: Apply one drop of the provided thread locker onto the studs.



12. Install the K&N® air filter onto the intake tube and secure with the provided hose clamp.

13. Double check to make sure everything is tight and properly positioned before starting the vehicle.

14. It will be necessary for all K&N® high flow intake systems to be checked periodically for realignment, clearance and tightening of all connections. Failure to follow the above instructions or proper maintenance may void warranty.

ROAD TESTING:

1. Start the engine with the transmission in neutral or park. Listen for air leaks or odd noises. For air leaks secure hoses and connections. For odd noises, find cause and repair before proceeding. This kit will function identically to the factory system except for being louder and much more responsive.

2. Test drive the vehicle. Listen for odd noises or rattles and fix as necessary.

3. If road test is fine, you can now enjoy the added power and performance from your kit.

4. K&N Engineering, Inc., suggests checking the air filter element periodically for excessive dirt build-up. When the element becomes covered in dirt (or once a year), service it according to the instructions on the Recharger® service kit, part number 99-5050 or 99-5000.

NOT LEGAL FOR SALE OR USE ON ANY POLLUTION CONTROLLED MOTOR VEHICLE IN CALIFORNIA OR STATES ADOPTING CALIFORNIA EMISSION PROCEDURES.

See knfilters.com for CARB status on each part for a specific vehicle