

Congratulations, you have purchased the finest exhaust system available for your motorcycle. Your Vance & Hines exhaust is designed and crafted for performance, quality, and style. Please follow the instructions below, check exhaust system for missing or damaged parts and if you need any assistance please contact our technical support line (562) 921-7461.

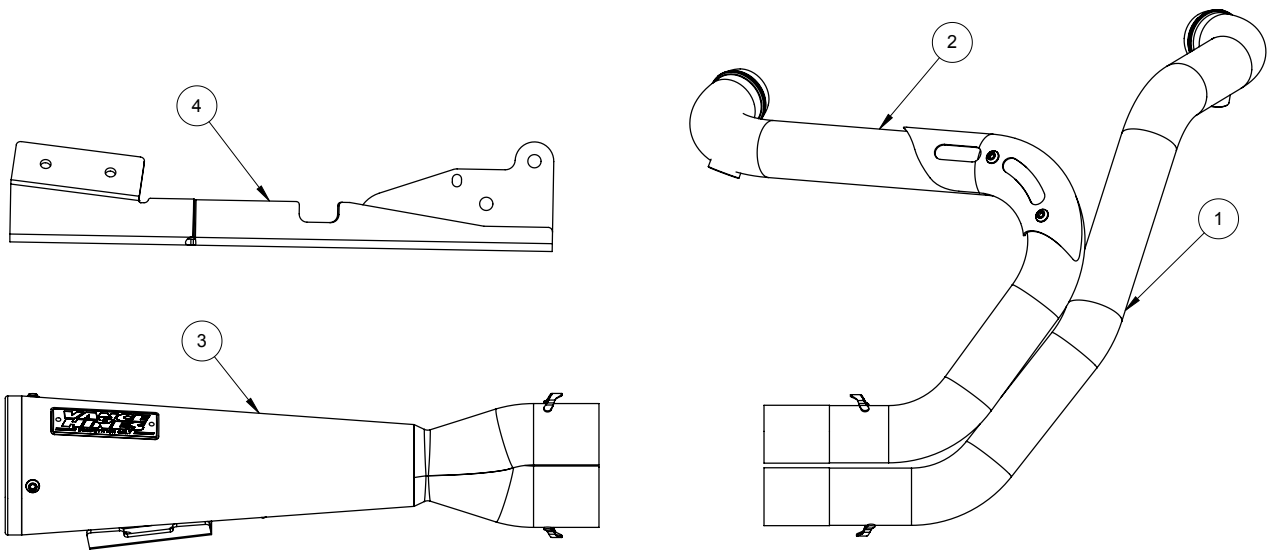

PARTS LIST

NO.	Part No.	Description	Qty.	NO.	Part No.	Description	Qty.
1	D1126FB / D1326FP	Front Head Pipe	1	8	A644ST	18-12mm O2 Adaptor	2
2	D1127FB / D1327FP	Rear Head Pipe	1	9	A914HW	3/8-16 x 7/8" SHCS	2
3	D370RB-S / D379RP-S	Muffler Can	1	10	A908HW	3/8-16 x 1" SHCS	2
4	1166-P	Mount Bracket	1	11	A121HW	18mm x 24mm Washer	2
5	1171-P	Footpeg Relocator	1	12	A240HW	5/16-18 x 5/8" FHS	2
6	A260SP	Spring Puller	1	13	A527HW	M18 O2 Bung Plug	2
7	A195HW	Dogbone Nut Plate	1	14	A115SP	Dirt Sport Spring	2

HARDWARE

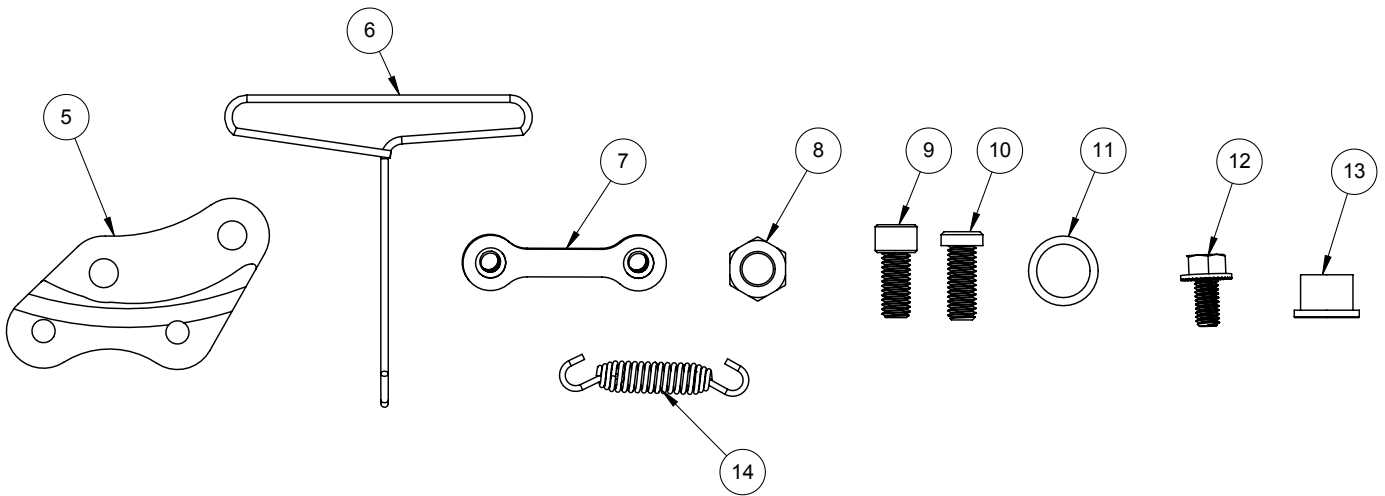

TOOLS REQUIRED

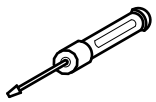

Screwdrivers - Flat blade, #3 Phillips Head

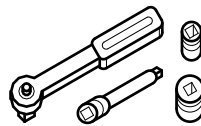

Ratchet & Extensions
Sockets - 1/2", 9/16" deep, 19mm

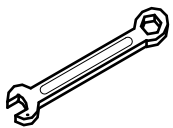

Combination Wrench - 1/2", 9/16", & 7/8" or 22mm, 14mm, 19mm

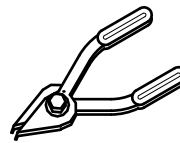

Snap Ring Pliers

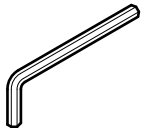

Allen Wrench - 3/16", 5/16"
Torx - T30

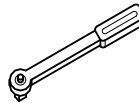

Torque wrench

STOCK EXHAUST SYSTEM REMOVAL

1. Locate and unplug the O₂ sensor wires from the wiring harness and remove nylon cable tie holding front wire to frame. Feed the end of the wires through the frame so they are free from the motorcycle. **NOTE:** Pay attention to wire routing for re-installation.
2. Loosen the heat shield clamps on both the front and rear exhaust pipes. This allows easier access to the head pipe mounting nuts.
3. Remove the two head pipe mounting nuts from each flange, located at the cylinder head.
4. Remove the clamp bolt which mounts the rear head pipe to the belt drive cover bracket.
5. Remove the two bolts from each muffler body where they attach to the mounting bar. Carefully remove exhaust pipes from the motorcycle and set aside.
6. Remove the drive belt cover and take the bracket off the rear cover bolt, the bracket will not be re-used.
7. **2014 - later** models, remove e-clip from brake rod lynchpin. Remove foot controls. **2004 - 2013** models remove the brake rod at the rear eyelet. Remove foot controls.
8. Remove the three mount bolts and washers attaching the exhaust mounting bar and remove bar. (Save hardware for re-use)
9. Carefully remove exhaust port flanges and circlips from the stock exhaust system using snapping pliers. **NOTE:** Replace bent or damaged circlips.
10. Check condition of exhaust gaskets and replace if worn or damaged. (Harley P/N - 65324-83B)

VANCE & HINES EXHAUST INSTALLATION

1. Install and tighten supplied mounting bracket (stamped 1169-P) using stock bolts and washers. Torque to 30-33 Ft/Lbs.
2. Re-install drive belt cover. Torque 1" x 3/8" bolt to 30-33 Ft/Lbs. and 2" x 1/4" bolts to 80-120 In/Lbs.
3. On bikes equipped with forward controls, install footpeg relocater (1171-P) using 2X A914HW and 2X A908HW. **(Figure 1)**
4. **2014 - later** models re-install brake rod, brake rod lynchpin and e-clip. Re-install foot controls. **2004 - 2013** models, re-install at brake rod eyelet using removable thread locking compound (Loctite ® 243 recommended). Torque to 120-180 In/Lbs.
5. Remove head pipes from protective packaging. Apply a small amount of anti-seize compound to the threads of the O₂ sensors and install them into the new head pipe. **NOTE: 2004 - 2006** and models not using O₂ sensors install supplied 18mm plug with copper crush washer. **2007 - 2013** models or models using 18mm wideband oxygen sensors install sensor directly into head pipe. **2014 - later** models install supplied 18mm to 12mm oxygen sensor adapter then install 12mm oxygen sensors.
6. Install exhaust port flanges and circlip from stock system onto the Vance and Hines head pipes.
7. Using stock flange nuts, carefully install head pipes into exhaust ports, starting with the rear cylinder. Assistance may be required. **NOTE:** Do not tighten at this time.
8. Install muffler assembly onto head pipes. Attach muffler assembly to installed bracket and secure with 5/16-18 flange bolt and dog bone nut plate (supplied).
9. Install springs using supplied spring puller. There should be about a 2" gap between the spring tabs **(Figure 2)**.
10. Tighten exhaust port flange nuts and 5/16" flange head bolts at the bracket.

VANCE & HINES EXHAUST INSTALLATION CONTINUED

11. Plug O2 sensors back into wiring harness and route wires away from hot areas of the motorcycle.
12. Check rear brake pedal function. If needed adjust rear brake linkage to increase clearance between brake pedal and rear cylinder heat shield.
13. Check for adequate clearance between all exhaust system components and motorcycle accessories prone to heat damage.
14. Be sure to tighten all hardware before starting your motorcycle.

EXHAUST CARE (STAINLESS)

1. When installing a new set of stainless pipes, make sure your hands are clean and free of oil. After installation, thoroughly clean pipes with a soft cloth and cleaning solvent that will leave no residue (glass cleaner, alcohol, acetone, etc...) before starting the motorcycle.
2. It is considered normal for stainless steel exhaust systems to discolor due to heat.
3. High performance engine tuning utilizing a dyno will likely result in severe discoloration.
4. Avoid long periods of idling as this can cause discoloration. Intake leaks can cause the engine to run lean and overheat and this could lead to discoloration.
5. Make sure there are no exhaust leaks at the junction of the exhaust pipes and cylinder head. We recommend replacing gaskets if they are worn.

EXHAUST CARE (BLACK)

1. When installing a new set of black pipes, make sure your hands are clean and free of oil. After installation, thoroughly clean pipes with warm soapy water and a soft cloth. Dry with a clean towel to remove any residue before starting the motorcycle. Do NOT use anything abrasive to clean the pipes.
2. Avoid long periods of idling as this can cause discoloration.
3. Intake leaks can cause the engine to run lean and overheat, this could lead to discoloration.

FIGURE 1



FIGURE 2

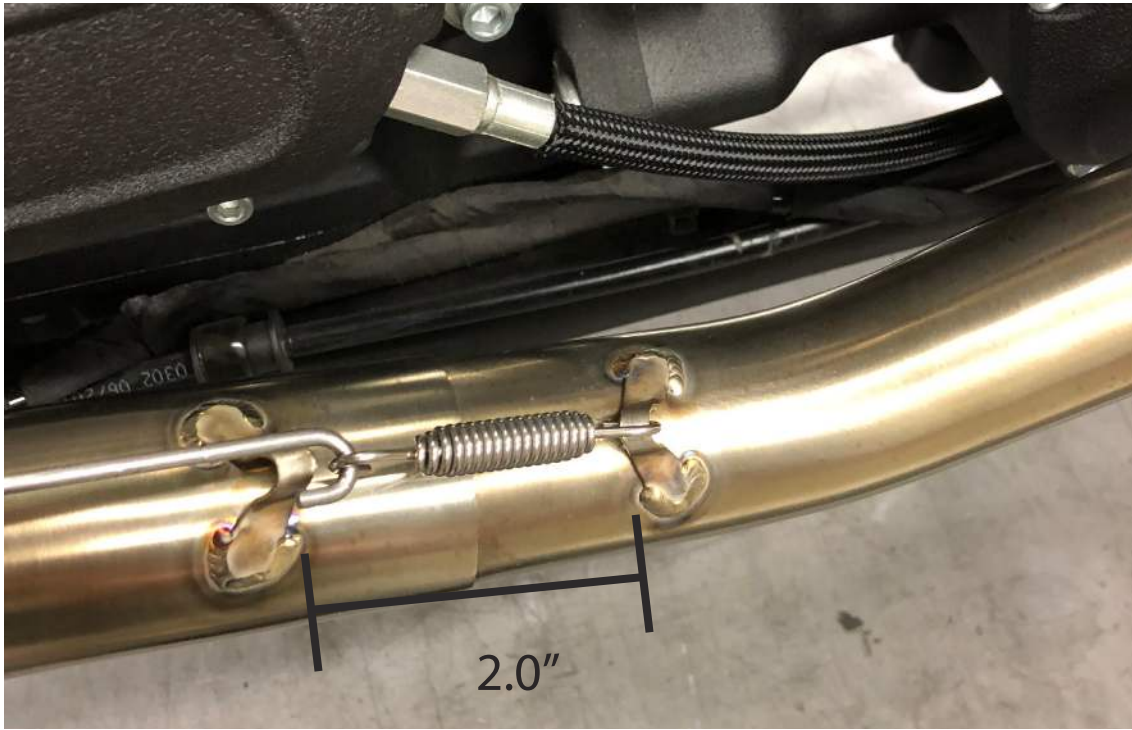

FIGURE 3



Emissions Notice:

In California, in order to meet Air Resources Board emissions requirements, certain aftermarket part applications have been identified as replacements, and others have received ARB Executive Orders. All other emissions related aftermarket parts are for competition use only. A list of replacement parts and EO parts, and corresponding fitment is provided at vanceandhines.com/california.

Warranty:

All Vance & Hines products are warranted against defects in material and workmanship for a period of 90 days. This warranty does not cover discoloration or rust. This warranty shall be limited to the repair or replacement of the product, which may be proven defective under normal use. Vance & Hines will not warranty any system that has been abused, misused, improperly installed or modified.

Dealers or distributors are not authorized to make dispositions binding upon Vance & Hines. Vance & Hines will not be responsible for any labor charges incurred in removing or replacing any system under warranty. A return authorization number and a copy of the original purchase invoice must accompany all returns. Parts returned without a return authorization may be refused.

THE NEXT GENERATION OF FUEL MANAGEMENT IS HERE

The Fuelpak FP3 will revolutionize fuel management for all new Harley-Davidson models now using the HDLAN (CAN Bus) system. Connecting wirelessly by Bluetooth to iPhone or Android Smartphones, Fuelpak FP3 uses Flash technology to recalibrate engine parameters and mapping for Vance & Hines exhaust systems downloaded from the expansive library of calibrations developed by Vance & Hines.

- Smartphone App User Interface (iOS and Android)
- Recalibrates ECM by Flash Tuning
- Autotune Feature for Added Tuning Precision
- Displays Live Sensor Data
- App Links Direct to Customer Service Site

FITMENT NOTES:

- FUELPK FP3 IS COMPATIBLE WITH CAN BUS MODELS ONLY (TOURING, SOFTAIL, DYNA & SPORTSTER)
- FUELPK FP3 IS NOT COMPATIBLE WITH V-ROD MODELS.
- MAPS ARE CURRENTLY AVAILABLE FOR: SPORTSTER, DYNA, SOFTAIL, TOURING AND TRIKE MODELS.
- MAPS FOR 110CI CVO MODELS COMING SOON.

EMISSIONS NOTICE:

FUELPK IS INTENDED FOR RACING USE ONLY, AND IS NOT LEGAL FOR SALE OR USE IN CALIFORNIA ON POLLUTION-CONTROLLED VEHICLES.



13861 ROSECRANS AVENUE / SANTA FE SPRINGS, CA 90670
SALES: (562) 921-5388
TECHNICAL: (562) 926-5291
FAX: (562) 802-0110

vanceandhines
.com